

# PTC

Power Train Components

YOUR PARTNERS FOR PROFIT!

## Not All Wheel Hub Assemblies Are Created Equal It's What You Can't See That Separates a Quality Unit from Other Units

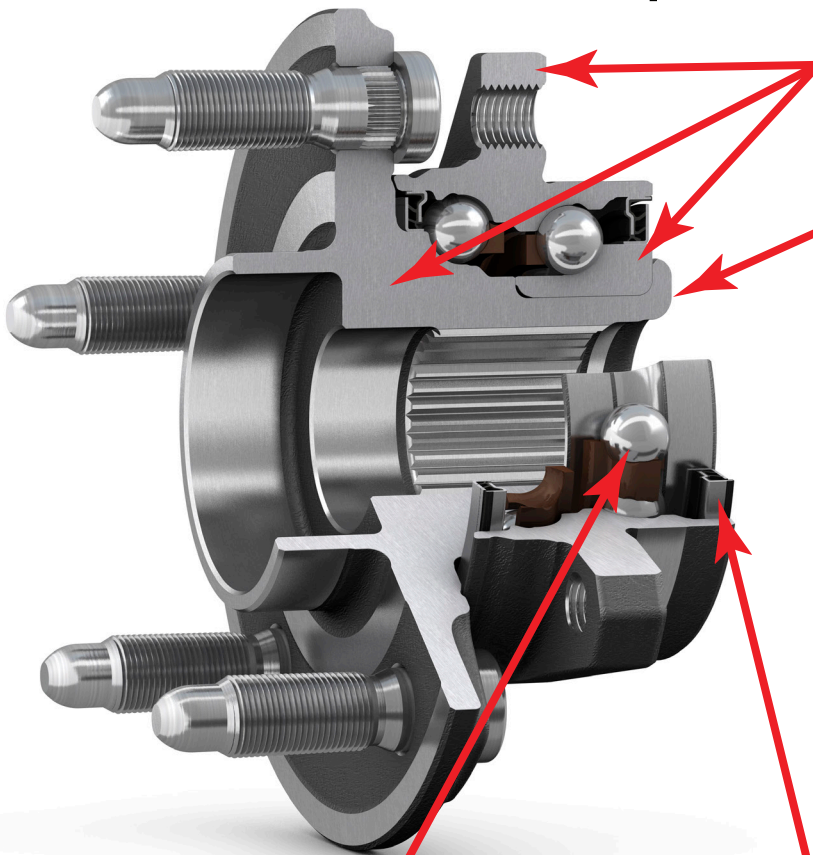

### Inner/Outer Ring & Flange

Premium grade high carbon steel is used to provide good mechanical properties and improve bearing performance

### Orbital Roll-Formed Design

Applies precise pre-load to enhance performance and decrease failure.

- Spindle is rolled over the top of the bearing
- Bearings are pre-loaded during roll-form process at the assembly stage
- Nut can no longer be over-tightened (available on select units)



### Waterproof Seal

A special waterproof seal ring with a dustproof structure provides better high temperature and wear resistance

### Surface Hardened Bearings

Special surface hardened bearings are highly resistant to premature wear and scratching which improves service life



### Premium Casted Metal Tone Ring

OE Style casted metal tone rings have rectangular teeth vs. cheaper pot metal tone rings with rounded teeth. This helps eliminate erratic ABS signals that can cause braking problems.

### Premium "Shell" Grease

Used to provide a better lubrication properties to reduce friction and wear over time.



We've got the right product, right quality & right price to help maximize your sales opportunities.

Call us today at 800.626.8333 to Order Your Needs!